

## MCSS/MCSP Current Switches

### INSTALLATION INSTRUCTIONS

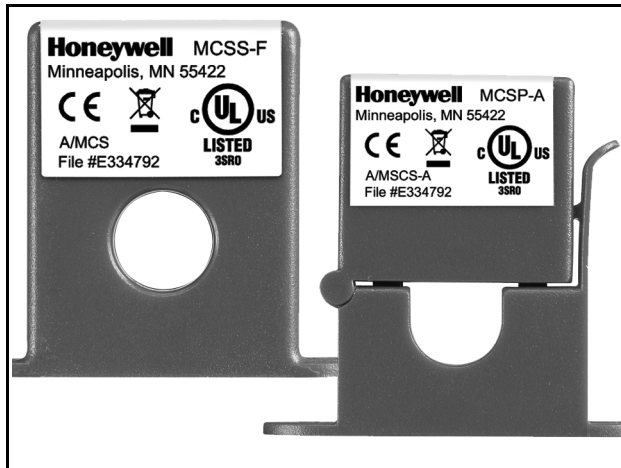

### INSTALLATION

Make sure that all installations are in compliance with all national and local electrical codes. Only qualified individuals that are familiar with codes, standards, and proper safety procedures for high-voltage installations should attempt installation. The current switches will not require external power, since the power for the current switch is induced from the conductor being monitored.



### CAUTION

**This product is not intended to be used for Life or Safety applications.**  
**This product is not intended for use in any hazardous or classified locations.**



### WARNING

**Risk of electrical shock.**

**Can cause severe injury, property damage or death.**

Disconnect and lock out all power sources before installation as severe injury or death may result from electrical shock due to contact with high voltage wires.

Never rely on the LED's of the MCSS-A/MCSP-A to determine whether power is present at the current switch. The Red LED will indicate whether the current is above the adjustable trip point. The Blue LED will indicate that the current is below the adjustable trip point.

The MCSS-A and MCSP-A Current Switches should be used on **Insulated Conductors Only!** The current switch may be mounted in any position using the (2) #8 x 3/4" Tek screws and the mounting holes in the base. Leave a minimum distance of 1" (3 cm) between the current switch and any other magnetic devices such as contactors and transformers.

For applications in which the normal operating current is below the 0.32Amps (MCSS-A) or 0.70Amps (MCSP-A) trip point (See Figure 5 below), the conductor being monitored may be looped through the sensor 6 times giving you a total operating current of 6X the original current. **Example:** A small fan operating at 0.2A should be wrapped through the sensor 7 times to give you a total operating current of 1.4 Amps flowing through the MCSS-A or MCSP-A.

For applications in which the normal operating current is greater than 150 Amps or for conductor diameters larger than 0.530" (1.35 cm) in diameter, an external 5 Amp Current Transformer (5A CT) must be used as shown in Figure 6 below. **Remember that the secondary of the 5A CT must be shorted together before the power may be turned onto the monitored device.**



# SPECIFICATIONS

Table 1. Operating specifications.

Model	Core Type	Switch Type	Trip Point	Output Switch Rating	Max. Sensing Current Voltage	Max. Continuous Current	Max. Current for 6 seconds	Max. Current for 1 second
MCSS-F	Solid	Fixed	< 0.20 Amps	0.50 Amp @ 36 VAC/VDC	600 VAC	158 Amps	240 Amps	600 Amps
MCSP-F	Split	Fixed	< 0.55 Amps					
MCSS-A	Solid	Adjustable	0.32 - 150 Amps	1.00 Amp @ 36 VAC/VDC				
MCSP-A	Split	Adjustable	0.70 - 150 Amps					

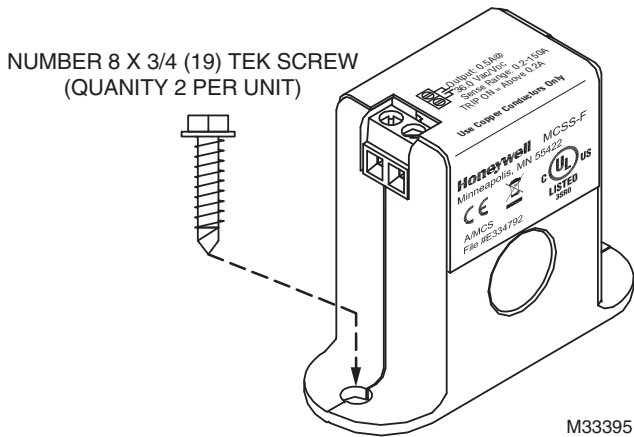

Fig. 1. MCSS-F

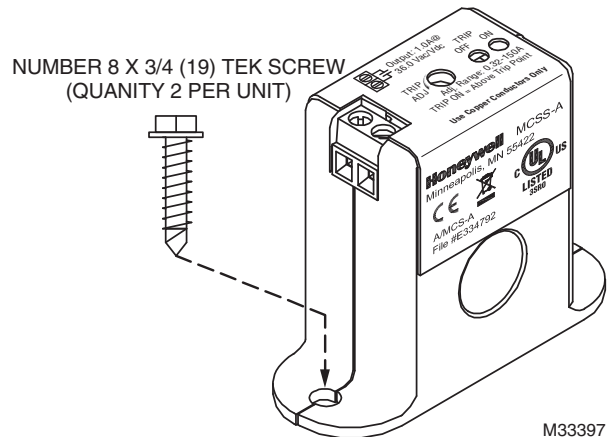

Fig. 3. MCSS-A

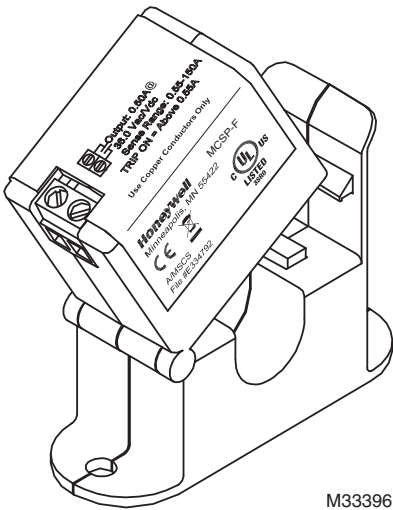

Fig. 2. MCSP-F

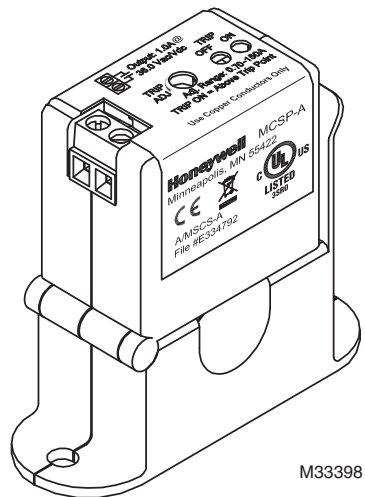

Fig. 4. MCSP-A

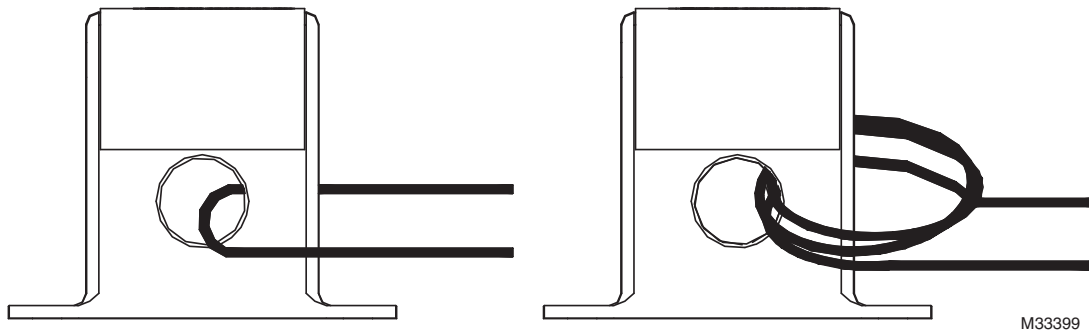

Fig. 5. Wires through sensors.

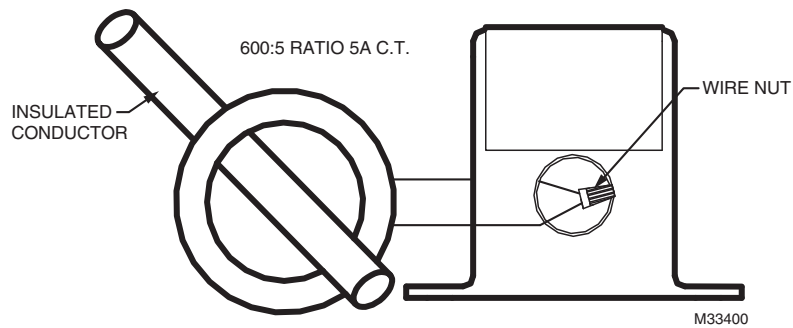

Fig. 6. Using a current transformer.

## WIRING

Honeywell recommends the use of a two conductor 16 to 22 AWG shielded cable or twisted pair **copper wire only** for all current switch applications. A maximum wire length of less than 30 meters (98.4 feet) should be used between the MCSS-A and MCSP-A current switches and the Building Management System or controller.

**NOTE:** When using a shielded cable, be sure to connect **only one (1) end of the shield to ground at the controller.** Connecting both ends of the shield to ground may cause a ground loop.

When removing the shield from the sensor end, make sure to properly trim the shield so as to prevent any chance of shorting. The current switch output terminals represent a solid-state switch for controlling both AC and DC loads and is not polarity sensitive. The recommended torque to be used on the terminal block connections is 0.67 Nm or 5.93 in-lbs.. The aperture (hole) size of the current switch is 0.53" (1.35 cm) and will accept a 1 AWG maximum wire diameter.

See Figure 7 and Figure 8 for two different current switch applications using your Building Management System (DDC/PLC Controller). Figure 7 is showing the use of the Go/No Go Current Switch as a Digital Input to your DDC Controller, whereas Figure 8 is showing you how to use the Go/No Go Current Switch in conjunction with your building management system to control a fan or pump for example.

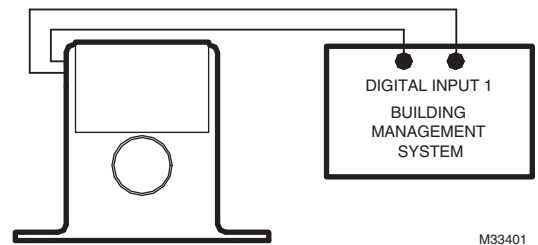

Fig. 7. Digital circuit.

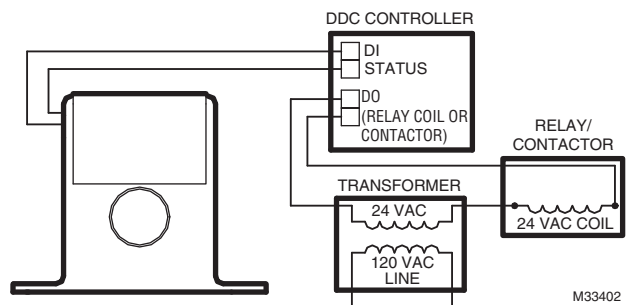

Fig. 8. Analog circuit.

## Calibration of Adjustable Trip Point (MCSS-A, MCSP-A models only)

The adjustable current switch has an operating range of 0-150 Amps. **Do not exceed!** The adjustable current switch comes with its fifteen-turn adjustment potentiometer set to the 100 Amp trip point position. The adjustable current switch can be used to monitor Under Load, Normal Load, and Over Load conditions, depending on how it's set. The procedure below is for the Normal load condition for part numbers MCSS-A & MCSP-A.

## Normal Loads (MCSS-A, MCSP-A models only)

With current flowing through the aperture of the MCSS-A and MCSP-A current switches, first verify that the Blue LED is on. If the Blue LED is on, now slowly adjust the potentiometer clockwise until the Red LED just turns on and stop immediately. This will set the trip point at your normal operating load current. If the RED LED is on after initial power up, this means that you will need to slowly adjust the potentiometer counter-clockwise until the Blue LED turns on and then slowly adjust the potentiometer clockwise until the Red LED just turns on and stop immediately. The adjustable current switch is now tripped. Now verify the output with an Ohmmeter to verify that the contacts of the switch are approximately 0.200 Ohms. The adjustable current switch Hysteresis (Dead Band) is typically 10% of the trip point.

**Table 2. Troubleshooting.**

Problem	Solution
Red LED is on but the current switch didn't activate (-A models) Current switch didn't activate (- F models)	Disconnect the wires from the current switch output. Measure the resistance across the contacts with an Ohmmeter.
Red LED didn't turn on and the current switch didn't activate (- A models) Current switch didn't activate (- F models)	Verify that the conductor you are monitoring is above the adjustable trip point. If the sensor is monitoring less than the minimum trip point, see Fig. 5.
Sensor doesn't switch at all, regardless of current level. (-A models)	Adjustment potentiometer is probably set to its maximum or minimum position. Turn the Pot counter-clockwise all the way and verify if the LED switches from Red to Blue.

By using this Honeywell literature, you agree that Honeywell will have no liability for any damages arising out of your use or modification to, the literature. You will defend and indemnify Honeywell, its affiliates and subsidiaries, from and against any liability, cost, or damages, including attorneys' fees, arising out of, or resulting from, any modification to the literature by you.

### Automation and Control Solutions

Honeywell International Inc.